



# Algas-SDI™

*...Innovative liquid vaporizing and gas mixing solutions*

ISO 9001  
Certified

# Vaporaire®

*Venturi LPG/Air mixer; Models V7.0 through V250.0*



**With Tank**



**Without Tank**

- *Provides an LPG/Air mixture to supplement or replace natural gas.*
- *Connects directly to existing natural gas fuel lines.*
- *Mixed gas delivery pressures available up to 15 psig for propane and 8 psig for butane without air assist.*
- *Mixed gas delivery pressures available up to 40 psig with air assist.*
- *Available with or without accumulator tank.*
- *No modifications to your burner equipment are necessary.*
- *No orifices to change and no sooting or fouling of combustion equipment.*
- *Complies with Class I, Division 1, Group D requirements.*
- *Compact and easy to service.*
- *100% Turndown.*

# Specifications

Capacity <sup>†</sup> Million BTU/Hr.	Delivery Pressure <sup>††</sup>						LPG Vapor Inlet (FNPT)	Outlet with tank	Outlet without Tank
	5 psig	8 psig	10 psig	12 psig	15 psig <sup>***</sup>	15-40 psig <sup>▲</sup>			
7	V7-5 <sup>†††</sup>	V7-8 <sup>†††</sup>		V7-12 <sup>†††</sup>			1"	4"-150# FLG	6"-150# FLG
10.5	V10.5-5 <sup>†††</sup>	V10.5-8 <sup>†††</sup>		V10.5-12 <sup>†††</sup>			1"	4"-150# FLG	6"-150# FLG
13			V13-10 <sup>†††</sup>				1"	4"-150# FLG	6"-150# FLG
14	V14-5 <sup>†††</sup>	V14-8 <sup>†††</sup>		V14-12 <sup>†††</sup>	V14-15 <sup>†††</sup>		1"	4"-150# FLG	6"-150# FLG
21	V21-5	V21-8		V21-12			1"	4"-150# FLG	6"-150# FLG
26			V26-10				1"	4"-150# FLG	6"-150# FLG
28	V28-5	V28-8		V28-12	V28-15	V28-PA	1"	4"-150# FLG	6"-150# FLG
35	V35-5	V35-8		V35-12			1½"	4"-150# FLG	6"-150# FLG
39			V39-10				1½"	4"-150# FLG	6"-150# FLG
42	V42-5	V42-8		V42-12	V42-15	V42-PA	1½" **	4"-150# FLG	6"-150# FLG
52			V52-10				1½"	4"-150# FLG	6"-150# FLG
56	V56-5	V56-8		V56-12	V56-15	V56-PA	1½" **	4"-150# FLG	6"-150# FLG
65			V65-10				2"	4"-150# FLG	6"-150# FLG
70	V70-5	V70-8		V70-12	V70-15	V70-PA	2"	4"-150# FLG	6"-150# FLG
78			V78-10				2"	4"-15-# FLG	6"-150# FLG
84	V84-5	V84-8		V84-12	V84-15	V84-PA	2"	4"-150# FLG	6"-150# FLG
100	V100-5	V100-8		V100-12 <sup>♦</sup>	V100-15 <sup>♦</sup>	V100-PA <sup>♦♦</sup>	2"	6"-150# FLG	8"-150# FLG
125	V125-5	V125-8		V125-12		V125-PA	2½"	6"-150# FLG	8"-150# FLG
150	V150-5	V150-8		V150-12	V150-15	V150-PA	3"	6"-150# FLG	8"-150# FLG
175	V175-5 <sup>♦♦♦</sup>	V175-8		V175-12		V175-PA	3"	6"-150# FLG	8"-150# FLG
200	V200-5	V200-8		V200-12		V200-PA <sup>♦♦</sup>	3"	8"-150# FLG	10"-150# FLG
225	V225-5	V225-8		V225-12		V225-PA	3"	8"-150# FLG	10"-150# FLG
250	V250-5	V250-8		V250-12		V250-PA	3"	8"-150# FLG	10"-150# FLG

\* Models V21-5 and V28-5 have a 1-½"NPT vapor inlet.

\*\* Models V42-5 and V56-5 have a 2"NPT vapor inlet.

\*\*\* All 15 PSI models use a 640 gallon accumulator tank.

▲ PA - Pressure assist. Only available without tank.

† Mixing capacities shown are approximate and may be adjusted by increasing or decreasing the LPG motive pressure. Capacity ratings based on a mixed gas gross heating value of 1450 BTU/SCF ± 5% with commercial grade propane.

†† Delivery pressures shown are valid up to 2000ft elevation.

††† Only available with accumulator tank. See ME mixer specification sheet.

♦ 6" Outlet.

♦♦ 8" Outlet.

♦♦♦ 10" Outlet.

Contact factory for information regarding applications at higher elevations.

Contact factory for shipping weights.

## Features

- Solid state progressive sequencer performs pre-programmed logic On/Off switching functions to accurately match each venturi to any flow demand (21-250 MMBTU/hr) (Bellows type pressure switch provided on 7-14 MMBTU/hr models).
- Adjustable mixed gas delivery pressures are available between: 4-5 psig, 6-8 psig, 9-10 psig, 11-12 psig, and 13-15 psig. Consult factory for adjustable ranges on air assist.
- Accumulator tanks are fabricated and stamped in accordance with ASME Unfired Pressure Vessel Code, Section VIII, Division 1.
- Accumulator tank design pressure: 50 psig and 650°F.

- 100% turndown capability.
- Low vapor pressure safety switch prevents rich mixtures from developing due to inadequate motive pressure.
- High mixed gas pressure safety switch prevents over pressurization of gas accumulator.
- Two or more units can easily be operated in parallel to meet the growing requirements of your business.
- All external metal surfaces are mechanically cleaned, primed, and painted.
- 120V/1ph electrical system (220V/1ph optional).
- Shipped complete with all operating and safety controls.

## Options

- Air intake silencers.
- Mixed gas BTU analyzer.
- Cabinet enclosure.

# Dimensions

\* Contact factory for inlet temperatures exceeding 180°F

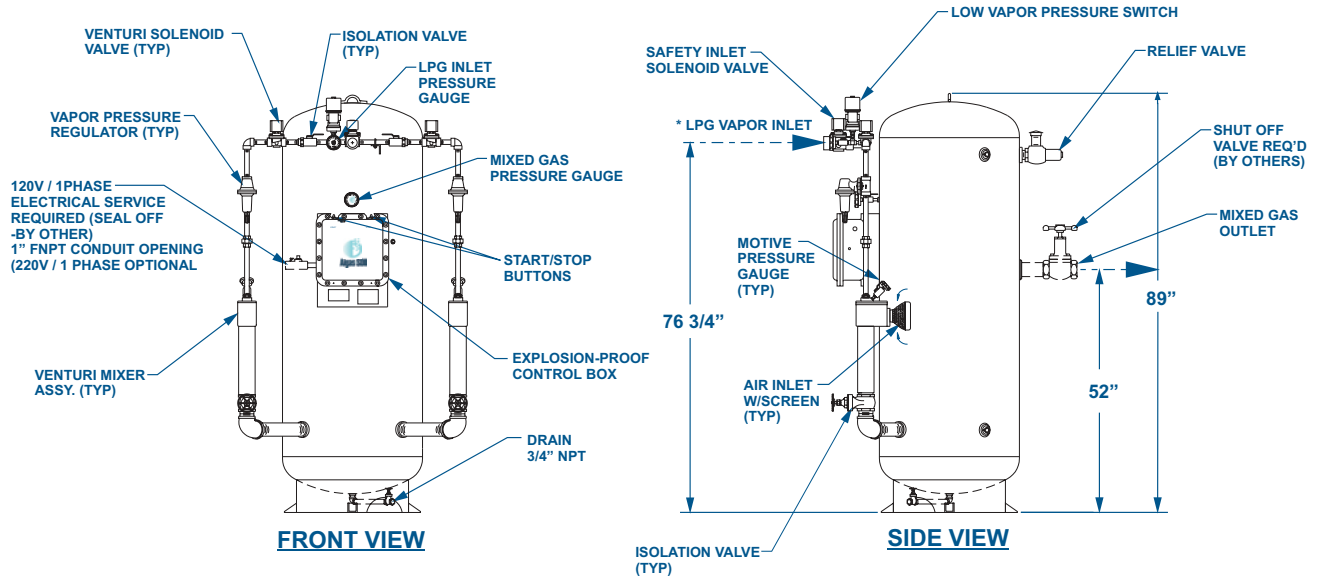

**V7.0 THRU V84.0**

FILE: VAPSPEC1.DWG

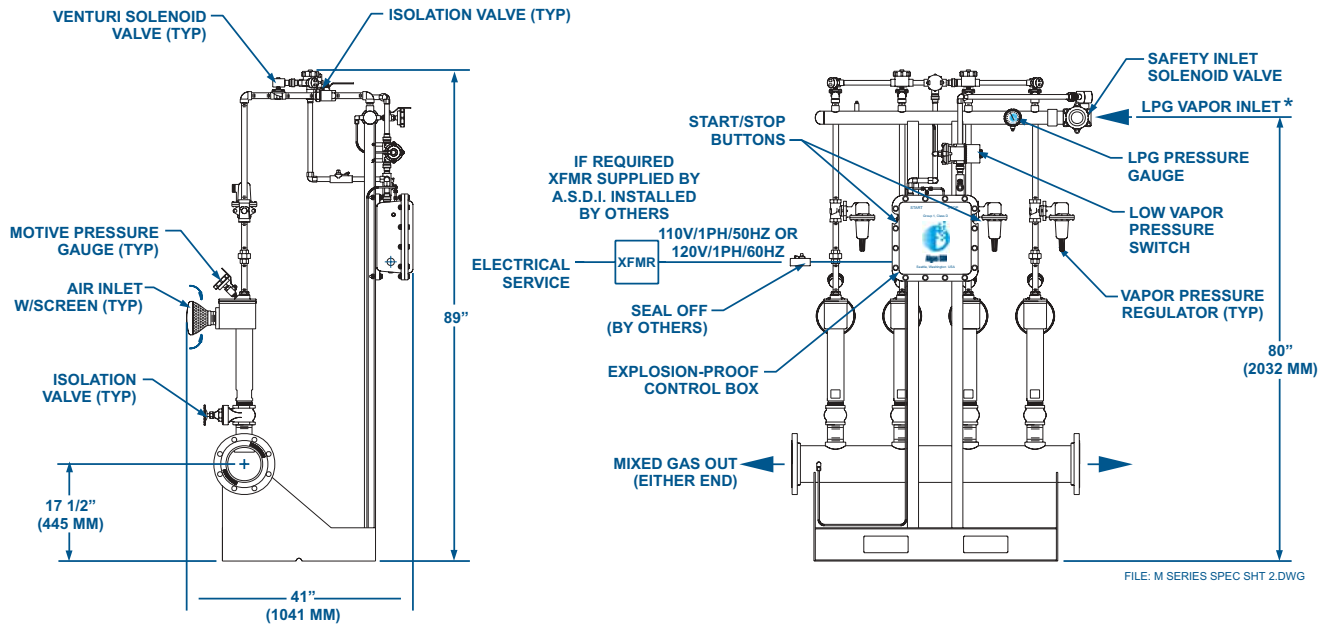

FILE: M SERIES SPEC SHT 2.DWG

# LPG Vapor Pressure Requirement Data

Mixed Air/Propane Delivery Pressure (psig)	Minimum Inlet Vapor Pressure (psig)
<b>Propane</b>	
5	31 - 51
8	70 - 76
10	99 - 109
12	110 - 120
15	160
<b>Butane</b>	
8	95
<b>Pressure Assist</b>	
15 - 40	70 - 90
<b>Contact factory for additional information</b>	

Product improvement is a continuing goal at Algas-SDI. Designs and specifications are subject to change without notice or obligation (contact factory for dimensions on V100 through V250).

NOTES:

1. BY OTHERS
2. INSTALL SYSTEM PER NFPA 58 AND 70 AND OTHER APPLICABLE CODES.
3. NO CHECK VALVES IN LIQUID LINE: LIQUID MUST BE ABLE TO FLOW IN BOTH DIRECTIONS.

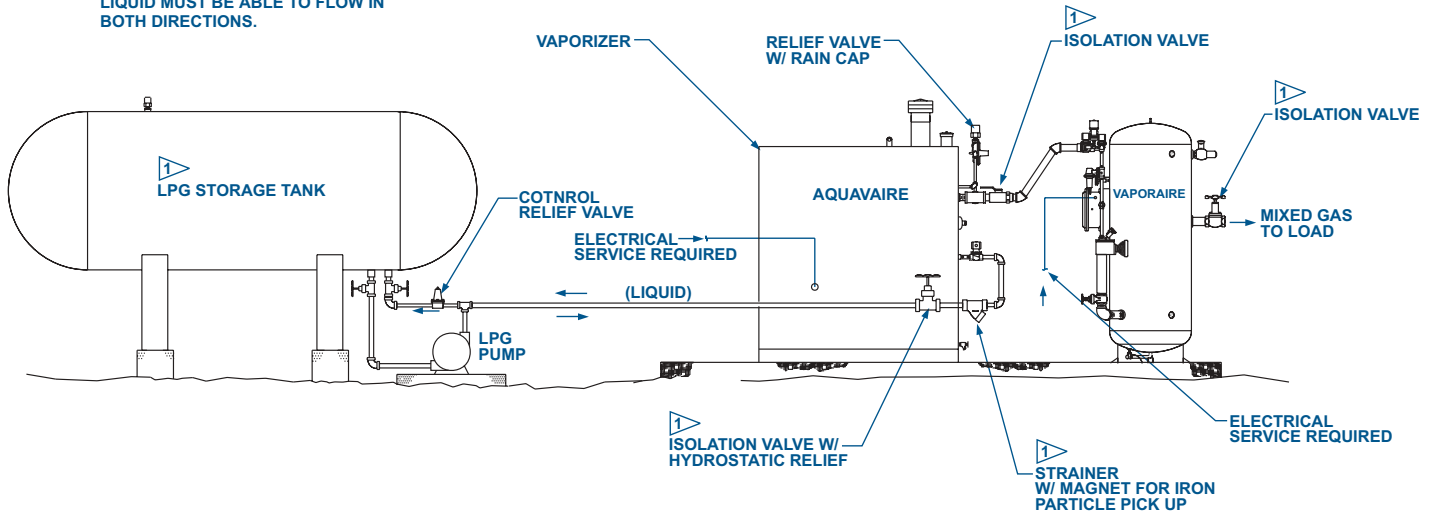

FILE: VAPSPEC2.DWG

VAPORAIRE® is a registered U.S. trademark of Algas-SDI.



**Home Office:**

1140 NW 46th Street  
 PO Box 70498  
 Seattle, Washington 98107 USA

Tel: 206.789.5410  
 Fax: 206.789.5414

e-mail: [sales@algas-sdi.com](mailto:sales@algas-sdi.com)  
 internet: [www.algas-sdi.com](http://www.algas-sdi.com)

*Represented By:*



2410 East 38<sup>th</sup> Street  
 Minneapolis, MN 55406-3018 USA

Tel: 612.721.4473  
 Fax: 612.724.8434

E-mail: [info@standby.com](mailto:info@standby.com)  
 Internet: <http://standby.com>



Form: VAP0401